



REMOTE CONTROLS
WITH FLEXIBLE CABLES

TC

TC



TC-TCC

Features

This catalog shows TC and TCC remote controls with flexible cables for directional control valves.

H Monoblock body TC or stackable TCC.

H Low actioning efforts.

H Easy installation.

H Detents, safety lever, several types of knob available.

H Two sizes available: TC5 recommended for SD4, SD5, SD6, SDM080 and DF5 valves; TC10 recommended for other valves.

Additional information

This catalog shows the product in the most standard configurations.

Please contact Customer Service Dpt. for more detailed information or special request.

WARNING!

All specifications of this catalog refer to the standard product at this date.

Walvoil, oriented to a continuous improvement, reserves the right to discontinue, modify or revise the specifications, without notice.

WALVOIL IS NOT RESPONSIBLE FOR ANY DAMAGE CAUSED BY AN
INCORRECT USE OF THE PRODUCT.

4th edition May 2000:

This edition supercedes all prior documents.

Connecting example

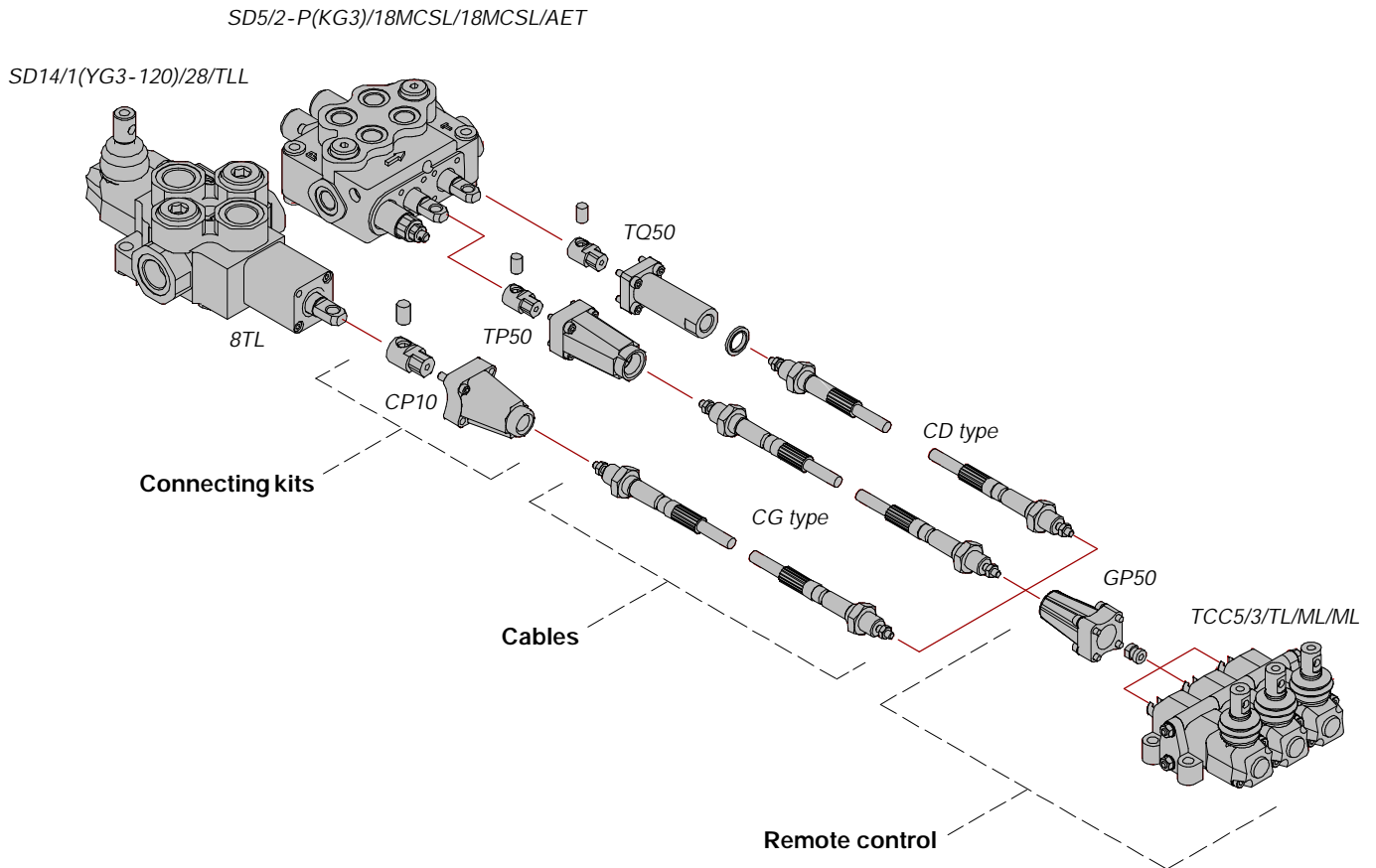

Contents

Monoblock remote control TC	4
Ordering codes	5
Stackable remote control TCC	6
Ordering codes	7
TC-TCC controls	8
Flexible cables	9
Connecting scheme	10
Connecting kits ordering codes	11

TC-TCC

TC5

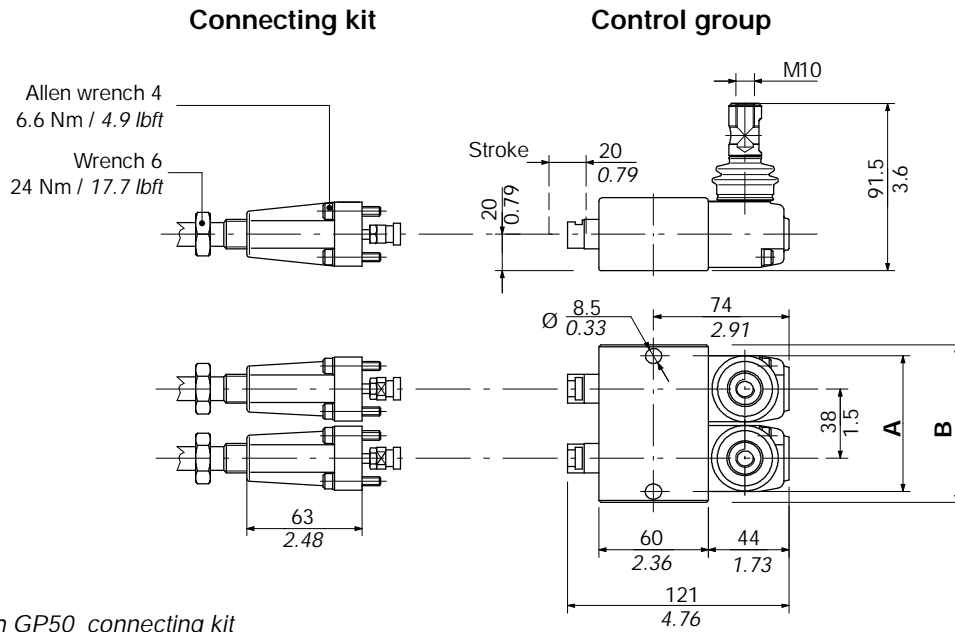

TC5/2 with GP50 connecting kit

TYPE	TC5/1		TC5/2		TC5/3		TC5/4	
	mm	in	mm	in	mm	in	mm	in
A	32	1.26	74	2.91	112	4.41	150	5.91
B	48	1.89	86	3.39	124	4.88	162	6.38

TC10

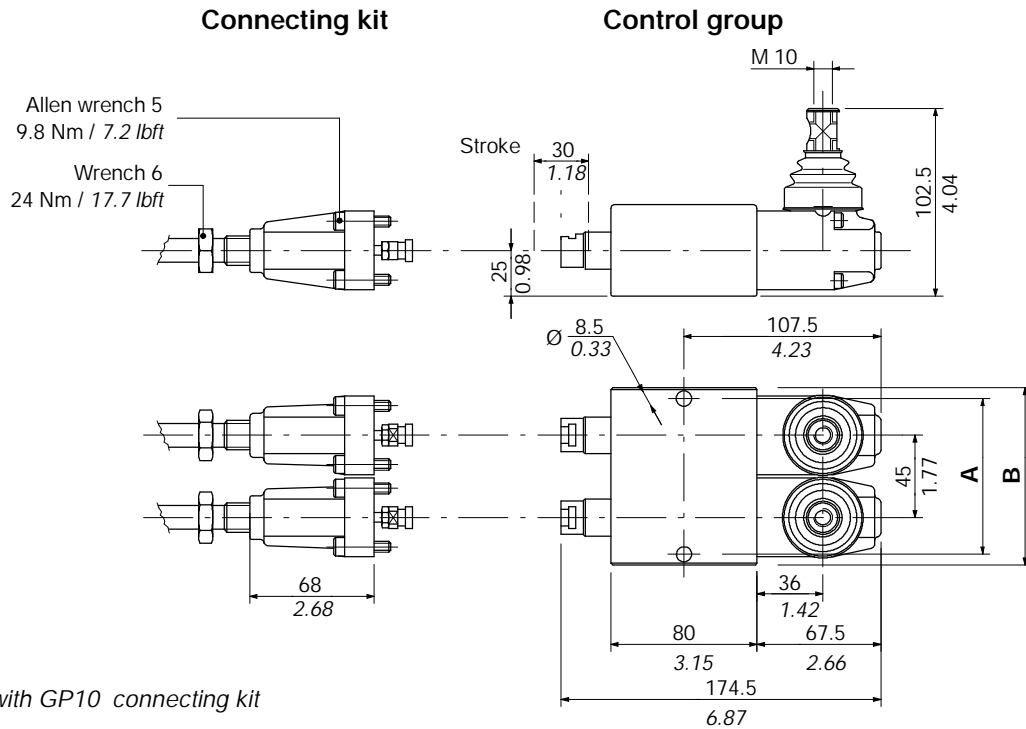

TC10/2 with GP10 connecting kit

TYPE	TC10/1		TC10/2		TC10/3		TC10/4	
	mm	in	mm	in	mm	in	mm	in
A	38	1.50	85	3.35	130	5.12	175	6.89
B	52	2.04	97	3.82	142	5.59	187	7.36

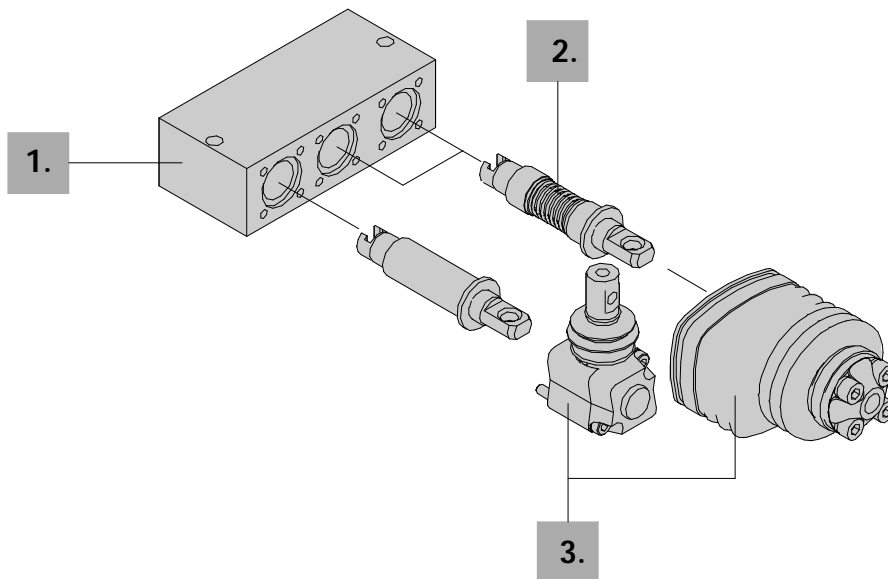
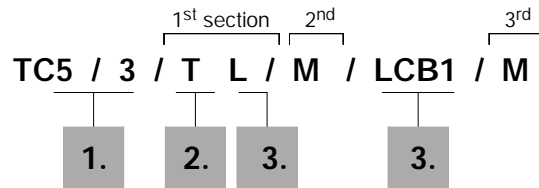

1. TC5 body

TYPE	CODE	DESCRIPTION
5/1	3COR111001	1 section
5/2	3COR112000	2 sections
5/3	3COR113000	3 sections
5/4	3COR114000	4 sections

2. TC5 positioning controls

TYPE	CODE	DESCRIPTION
M	5GIU316990	spring centered
T	5GIU316992	without spring return

3. TC5 actuating controls

TYPE	CODE	DESCRIPTION
L	5LEV205010	M10 lever
SLP	5COP105010	without lever with dust cover plate
LCB	5CLO206105	LCB6 mechanical joystick
LEB	5LEV605050	safety lever with lock in neutral

1. TC10 body

TYPE	CODE	DESCRIPTION
10/1	3COR121800	1 section
10/2	3COR122000	2 sections
10/3	3COR123000	3 sections

2. TC10 positioning controls

TYPE	CODE	DESCRIPTION
M	5GIU320990	spring centered
T	5GIU320991	without spring return

3. TC10 actuating controls

TYPE	CODE	DESCRIPTION
L	5LEV110015	M10 lever
SLP	5COP110010	without lever with dust cover plate
LCB	5CLO211100	LCB11 mechanical joystick

TC-TCC

TCC5

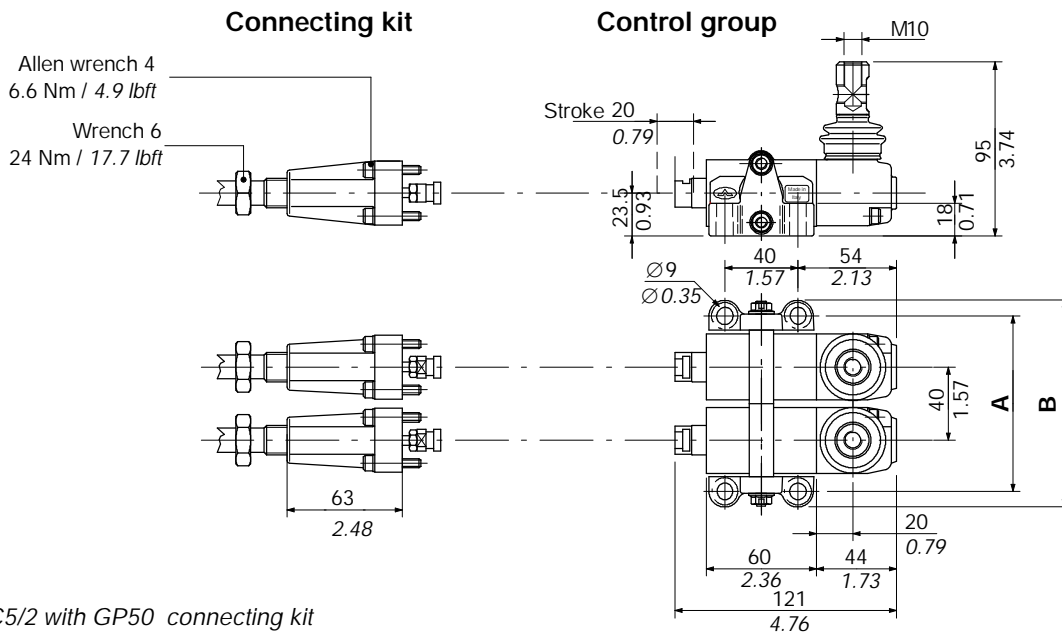

TCC5/2 with GP50 connecting kit

TYPE	TCC5/1		TCC5/2		TCC5/3		TCC5/4		TCC5/5		TCC5/6		TCC5/7	
	mm	in	mm	in	mm	in	mm	in	mm	in	mm	in	mm	in
A	56	2.20	96	3.78	136	5.35	176	6.93	216	8.50	256	10.08	296	11.65
B	73	2.87	113	4.45	153	6.02	193	7.6	233	9.17	273	10.74	313	12.32

TCC10

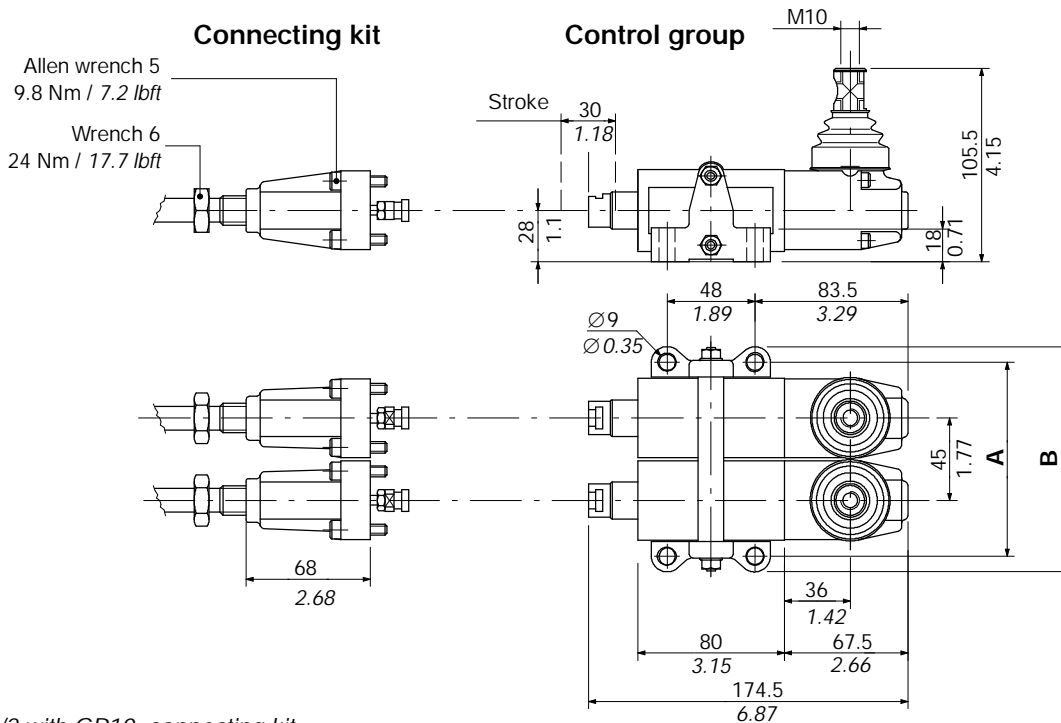

TCC10/2 with GP10 connecting kit

TYPE	TCC10/1		TCC10/2		TCC10/3		TCC10/4		TCC10/5		TCC10/6		TCC10/7	
	mm	in	mm	in	mm	in	mm	in	mm	in	mm	in	mm	in
A	61	2.4	106	4.17	151	5.94	196	7.72	241	9.49	286	11.26	331	13.03
B	78	3.07	123	4.84	168	6.61	213	8.39	258	10.16	303	11.93	348	13.70

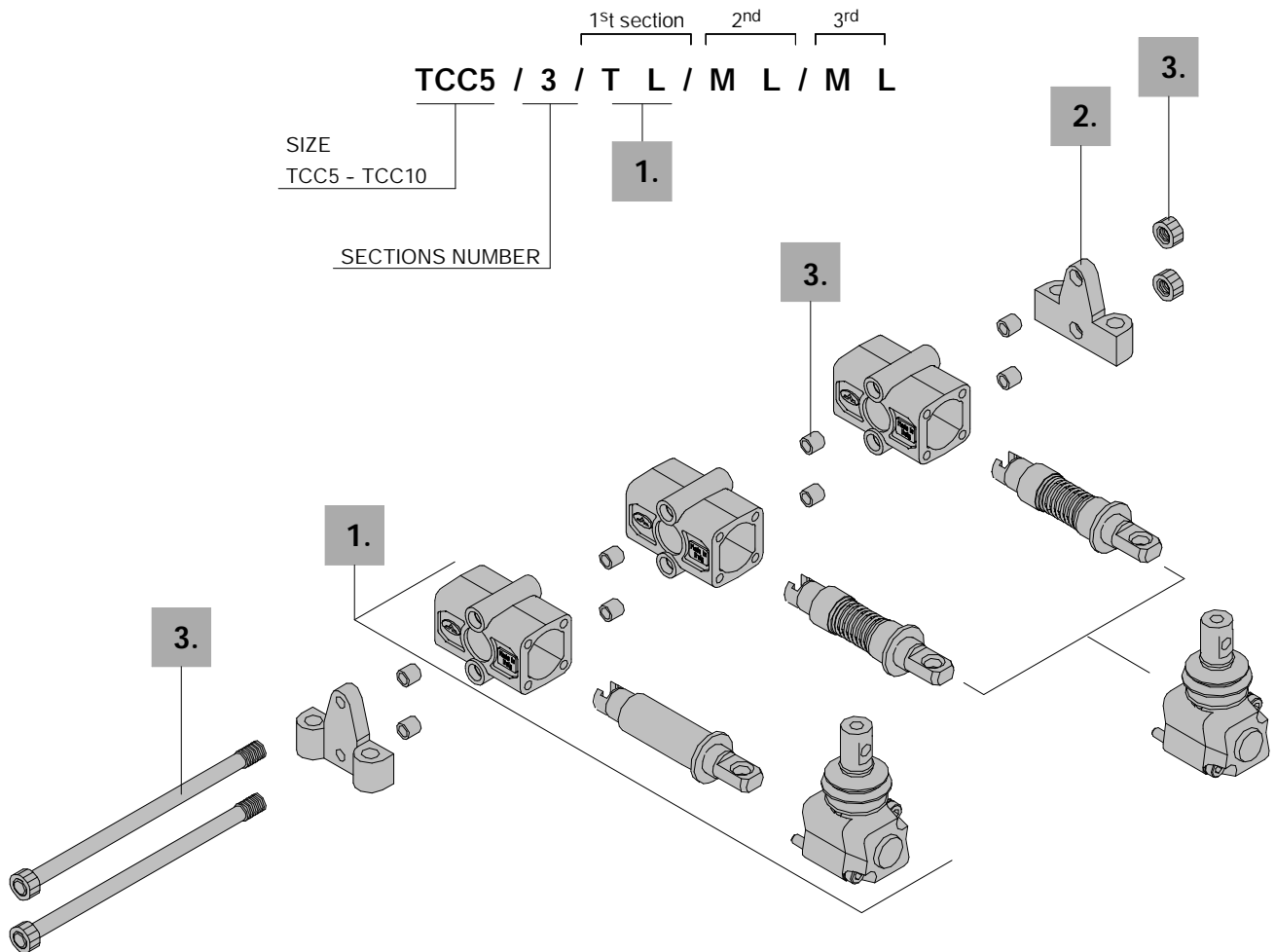

NO TAG TCC5 complete sections

TYPE	CODE	DESCRIPTION
ML	6TEL005100	with lever and spring return
TL	6TEL005200	with lever, without spring return
UL	6TEL005211	with lever, movement selector and without spring (only to be used as first or last section)
ULEB	6TEL005212	with safety lever (lock in neutral), movement selector and without spring (only to be used as first or last section)

2. TCC5 fixing brackets

CODE	DESCRIPTION
5STA346057	standard support
5STA346058	U selector support

3. TCC5 tie rod kits

CODE	GROUP	CODE	GROUP
5TIR106073	TCC5/1	5TIR106233	TCC5/5
5TIR106113	TCC5/2	5TIR106273	TCC5/6
5TIR106153	TCC5/3	5TIR106313	TCC5/7
5TIR106193	TCC5/4		

NO TAG TCC10 complete sections

TYPE	CODE	DESCRIPTION
ML	6TEL010100	with lever and spring return
TL	6TEL010200	with lever, without spring return

2. TCC10 fixing brackets

CODE	DESCRIPTION
5STA354065	standard support

3. TCC10 tie rod kits

CODE	GROUP	CODE	GROUP
5TIR106078	TCC10/1	5TIR106258	TCC10/5
5TIR106123	TCC10/2	5TIR106303	TCC10/6
5TIR106168	TCC10/3	5TIR106348	TCC10/7
5TIR106213	TCC10/4		

TC-TCC

Controls

M controls

Spring centered to neutral.

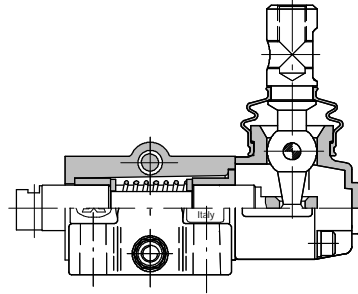
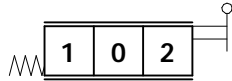

T controls

Without spring return for detented controls on directional valve and control without neutral position.

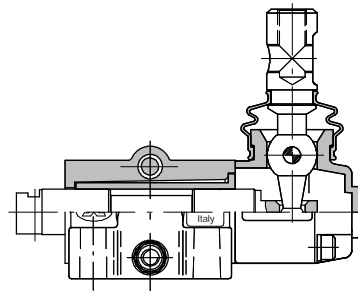
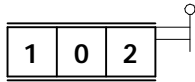

U controls (TCC5 only)

With 3 detented positions (only to be used as first or last sections).

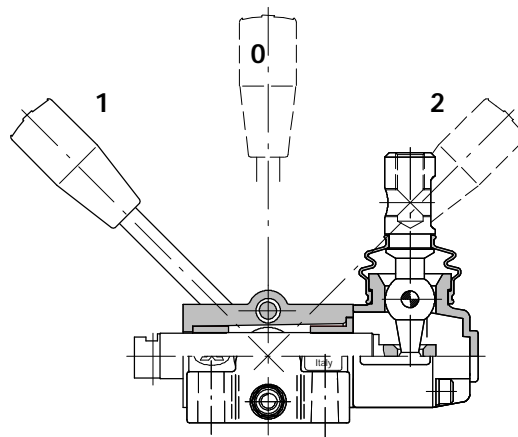
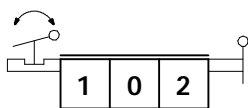

Technical data

Maximum admissible traction load	1450 N	340 lb
Maximum admissible compression load	880 N	200 lb
Minimum recommended bend radius	R = 150 mm	5.9 in
Working temperature	from -40 to 80 °C	-40B176° F
Maximum recommended length	4000 mm	157.48 in

CG cable

Flexible cable with both turning ends.

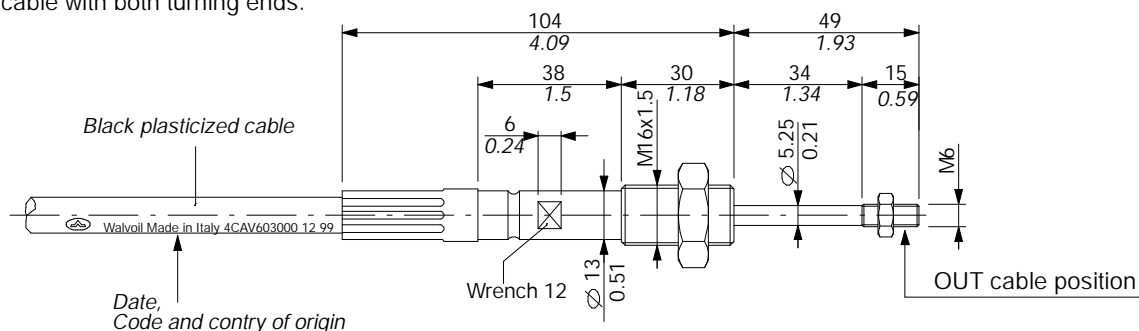

Yellow galvanized turning end

CD cable

Flexible cable with one fixing end and one turning end (see CG cable).

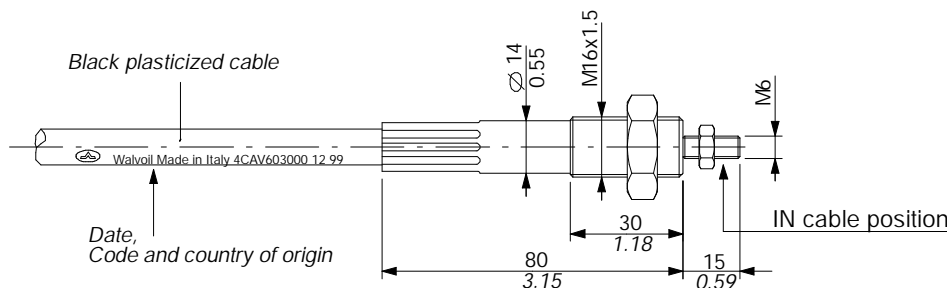

Yellow galvanized fixing end

Ordering codes

Flexible cables CD 2000

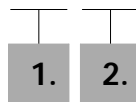

1. Type	2. Cables length mm - in									
	500 19.68	750 29.52	1000 39.37	1250 49.20	1500 59.05	2000 78.71	2500 98.42	3000 118.11	3500 137.79	4000 157.48
CD										
4CAV60	0500	0750	1000	1250	1500	2000	2500	3000	3500	4000
CG										
4CAV70	0500	0750	1000	1250	1500	2000	2500	3000	3500	4000

Ex: flexible cable CD2000 - code 4CAV602000

Connecting scheme

Flexible cables and connecting kit at both ends are used to join control group, TC or TCC, to the directional control valve.
 On the remote control there is always a GP kit; on the valve, kit type depends on the cable.
 TP kit is used with CG cable with turning ends; TQ is a waterproof kit used with the fixing end of CD cable.
 CP kit must be used instead of TP kit when TL control is mounted on the valve, with the lever on the opposite side.

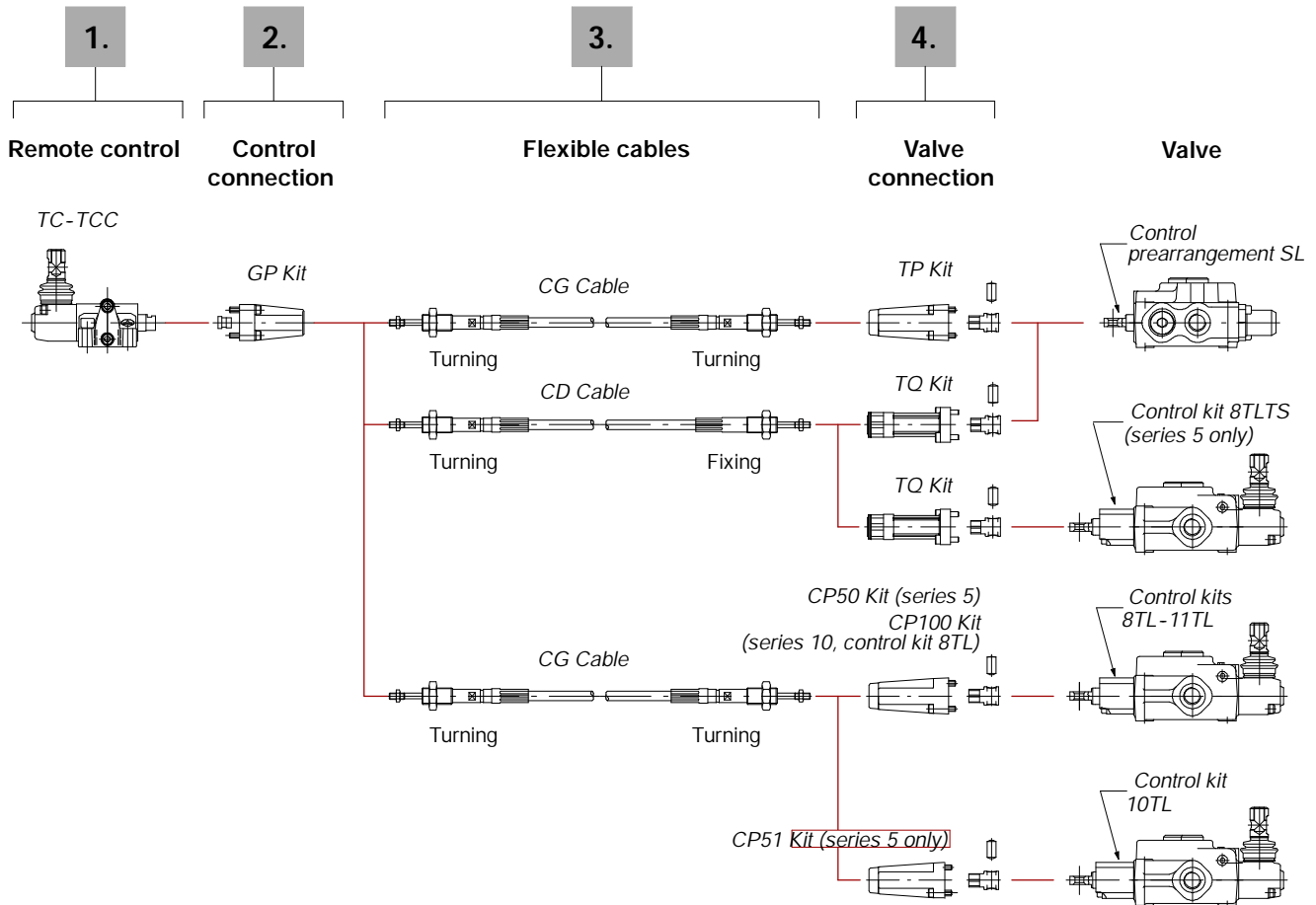

1. **2.** **3.** **3.** **4.** **4.**

TCC5/3/TL/ML/ML + GP50x3 + CG2000x2 + CD2000 + TP50x2 + CP100 + SD5/2-P(KG3-120)/18MCSL/18MCSL/AET + SD14/1(YG3-120)/28TLL

1. TC remote control page 5

TCC remote control page 7

3. Flexible cables page 9

TYPE	CODE	DESCRIPTION
2000D	4CAV602000	cable CD 2000
2000G	4CAV702000	cable CG 2000

2. Control connection kit

TYPE	CODE	DESCRIPTION
GP50	5TEL005005	Kit for TC5-TCC5
GP100	5TEL010005	Kit for TC10-TCC10

4. Valve connection kit

TYPE	CODE	DESCRIPTION
<u>TP: for turning end</u>		
TP50	5TEL105005	Kit for series 5 (SD4-SD5-SD6-SDM080-DF5)
TP81	5TEL108200	Kit for SDM143-DLM142
TP100	5TEL110005	Kit for series 10 (SDS150-SD11-SD14-SD16-DF10)
TP200	5TEL120005	Kit for series 20 (SD18-SD25-DF20)
<u>TQ: for fixing end</u>		
TQ50	5TEL105110	Kit for series 5 (SD4-SD5-SD6-SDM080-DF5)
TQTL50	5TEL105101	Kit to be used with 8TLTS controls on series 5 valve (SD4-SD5-SD6-SDM080-DF5)
TQ70	5TEL107100	Kit for SDM102-DLS7
TQ80	5TEL108110	Kit for SD8-SDM140-SDM141
TQ81	5TEL108220	Kit for SDM143-DLM142
TQ100	5TEL110110	Kit for series 10 (SDS150-SD11-SD14-SD16-DF10)
TQ200	5TEL120100	Kit for series 20 (SD18-SD25-DF20)
<u>CP: for turning end and lever on the opposite side of the valve</u>		
CP50	5TEL405005	Kit for series 5 (SD4-SD5-SD6-SDM080-DF5) to be used with 8TL-11TL-17TL controls
CP51	5TEL405011	Kit for series 5 (SD4-SD5-SD6-SDM080-DF5) to be used with 10TL controls
CP100	5TEL410005	Kit for series 10 to be used with 8TL (SDS150-SD11-SD14-SD16-DF10) control



WALVOIL S.P.A.

42100 REGGIO EMILIA • ITALY • VIA ADIGE, 13/D
TEL. +39.0522.932411 • FAX +39.0522.300984
E-MAIL: INFO@WALVOIL.COM • HTTP: //WWW.WALVOIL.COM

SALES DEPARTMENT

TEL. +39.0522.932555 • FAX +39.0522.932455

DFC030A